

DW3 DW4

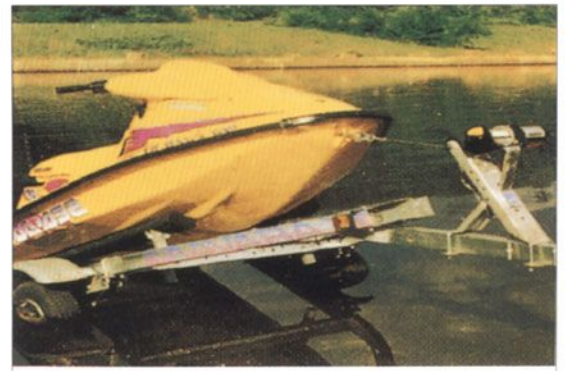

A super addition for boat trailers

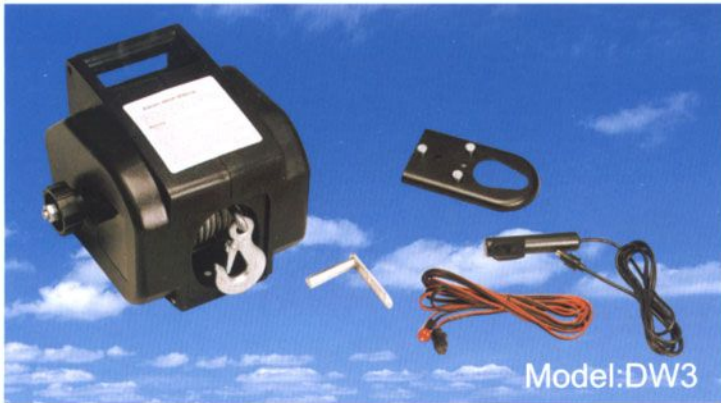

● 12V直流电动绞盘 ELECTRIC WINCH

产品型号 Specification	额定电压 DC(V)	最大负载 Capacity (Lbs)	绳长 Cable length m(ft)	每件数量 Quan/CTN (PCS)	包装尺码 Packing dimension(cm)	毛重/净重 G.W./N.W. (kg)
DW3	12	2000	9.0(30)	2	60×37×27	24/22
DW4	12	3000	9.0(30)	1	35×34×25	16/15

DW 5000

DW 8000

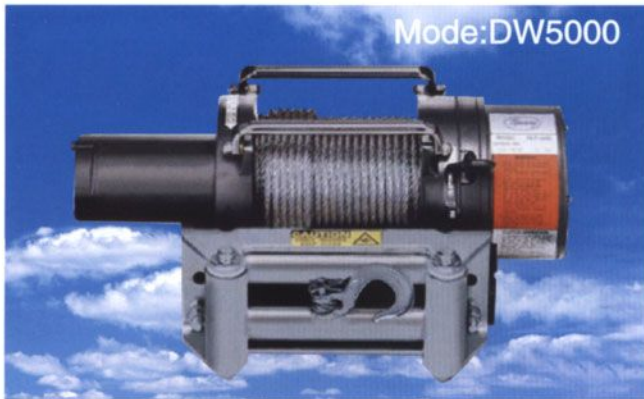

● 12V直流电动绞盘 ELECTRIC WINCH

产品型号 Specification	额定电压 DC(V)	最大负载 Capacity (Lbs)	绳长 Cable length m(ft)	绳径 Cable Dia	绳筒长度 Drum length	绳筒外径 Drum Dia
DW-5000	12	5000	24(80)	6.1mm(1/4")	140mm(5.5')	63mm(2.48')
DW-8000	12	8000	29(95)	8mm(5/16")	230mm(9')	63mm(2.48')

DW1 DW2



Great loading tool for pickups and trailer

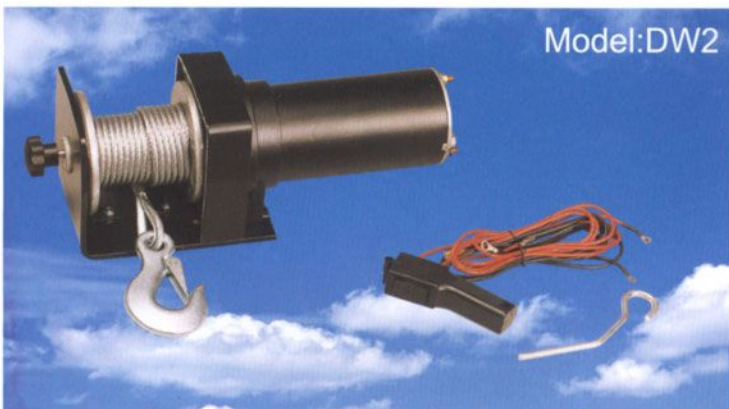

Ideal for ATV's, snow-mobiles, and other recreational uses

● 12V直流电动绞盘 ELECTRIC WINCH

产品型号 Specification	额定电压 DC(V)	最大负载 Capacity (Lbs)	绳长 Cable length m(ft)	每件数量 Quan/CTN (PCS)	包装尺码 Packing dimension(cm)	毛重/净重 G.W./N.W. (kg)
DW1	12	2000	7.6(25)	2	46×39×22	16/15
DW2	12	1500	7.6(25)	4	37×33×35	26/25



HST-250-1100

HST-300-1100

HST-600-750

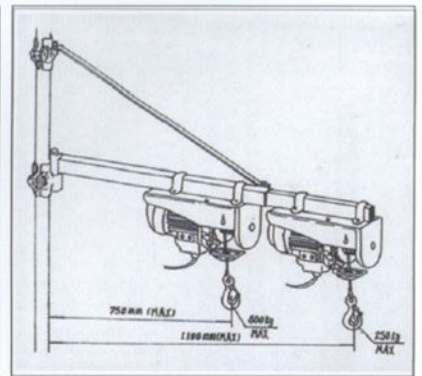
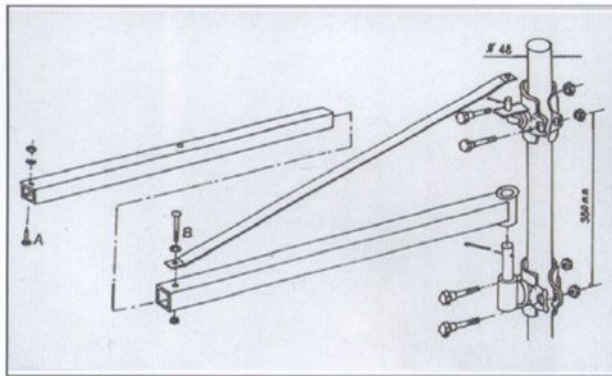
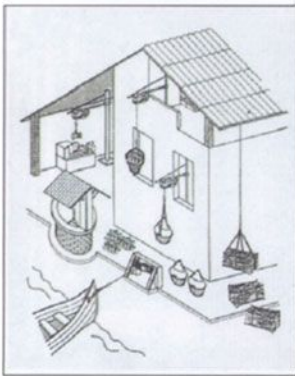
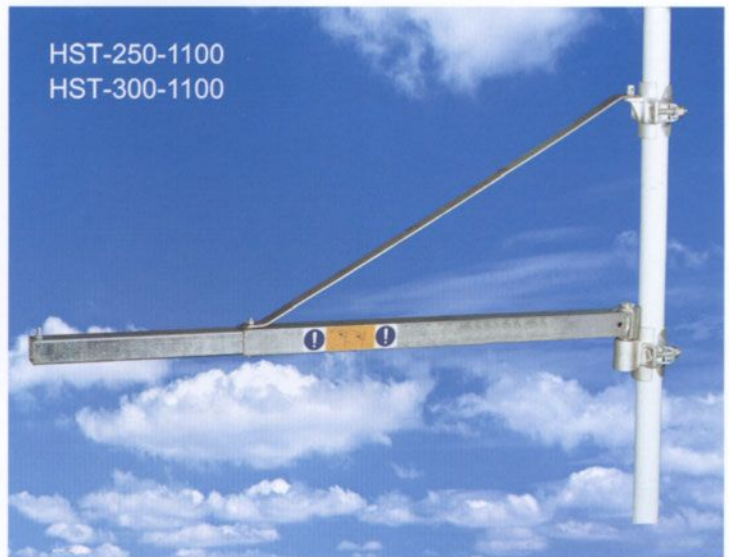

● 回旋伸缩式葫芦架 ROTARY HOIST FRAME

产品型号 Specification	额定悬挂重量 Rated hanging weight(kg)	最大伸出长度 Rated lifting length(mm)	每件数量 Quan/CTN (PCS)	包装尺码 Packing dimension(cm)	毛重/净重 G.W./N.W. (kg)
HST-250-1100	250	1100	4	86×22×20	32/30
HST-300-1100	300	1100	4	86×22×20	32/30
HST-600-750	600	750	4	86×22×20	24/22

手动绞盘

Hand winch



HW2000

2000Lbs capacity

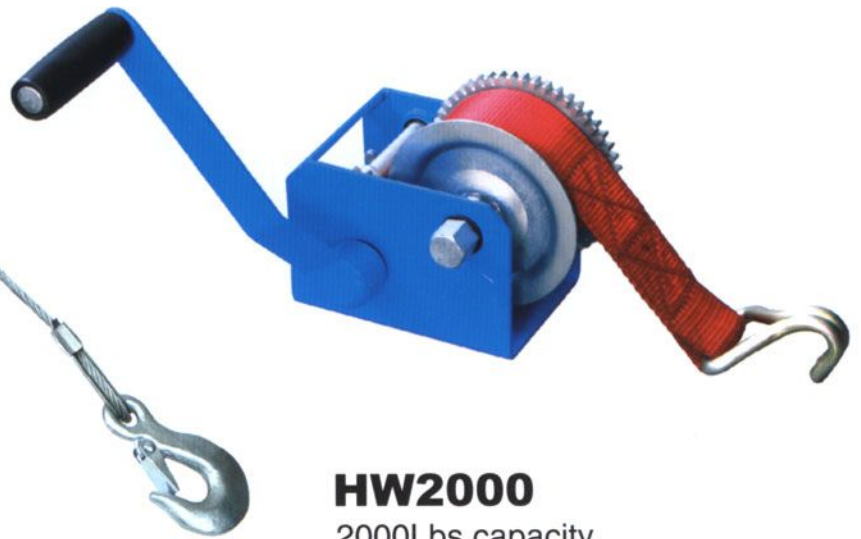

HW2000

2000Lbs capacity



HW2500

2500Lbs capacity



HW2500

2500Lbs capacity

● 手动绞盘 HAND WINCH

产品型号 Specification	额定负载 Capacity (Lbs)	绳长 Cable length m(ft)	每件数量 Quan/CTN (PCS)	包装尺码 Packing dimension(cm)	毛重/净重 G.W./N.W. (kg)
HW2000	2000	7.6(25)	6	49.5×44×17.5	30/28
HW2500	2500	7.6(25)	6	49.5×44×17.5	32/30

PA200

PA250

PA300



● 电动葫芦 ELECTRIC HOIST

产品型号 Specification	使用方法 Method of use	额定电压 Rated volt(V)	输入功率 Input power (W)	额定起重量 Rated lifting weight(kg)	起升速度 Lifting speed (m/min)	起升高度 Lifting height (m)	每件数量 Quan/CTN (PCS)	包装尺码 Packing dim- ension(cm)	毛重/净重 G.W./N.W. (kg)
HGS-B100-12 PA200	单钩 Single-hook	220/230	450	100	10	12	2	46×36×16	24/22
	双钩 Double-hook			200	5	6			
HGS-B125-12 PA250	单钩 Single-hook	220/230	500	125	10	12	2	46×36×16	25/23
	双钩 Double-hook			250	5	6			
HGS-B150-12 PA300	单钩 Single-hook	220/230	550	150	10	12	2	46×36×16	26/24
	双钩 Double-hook			300	5	6			

PA400 PA500 PA600 PA700 PA800

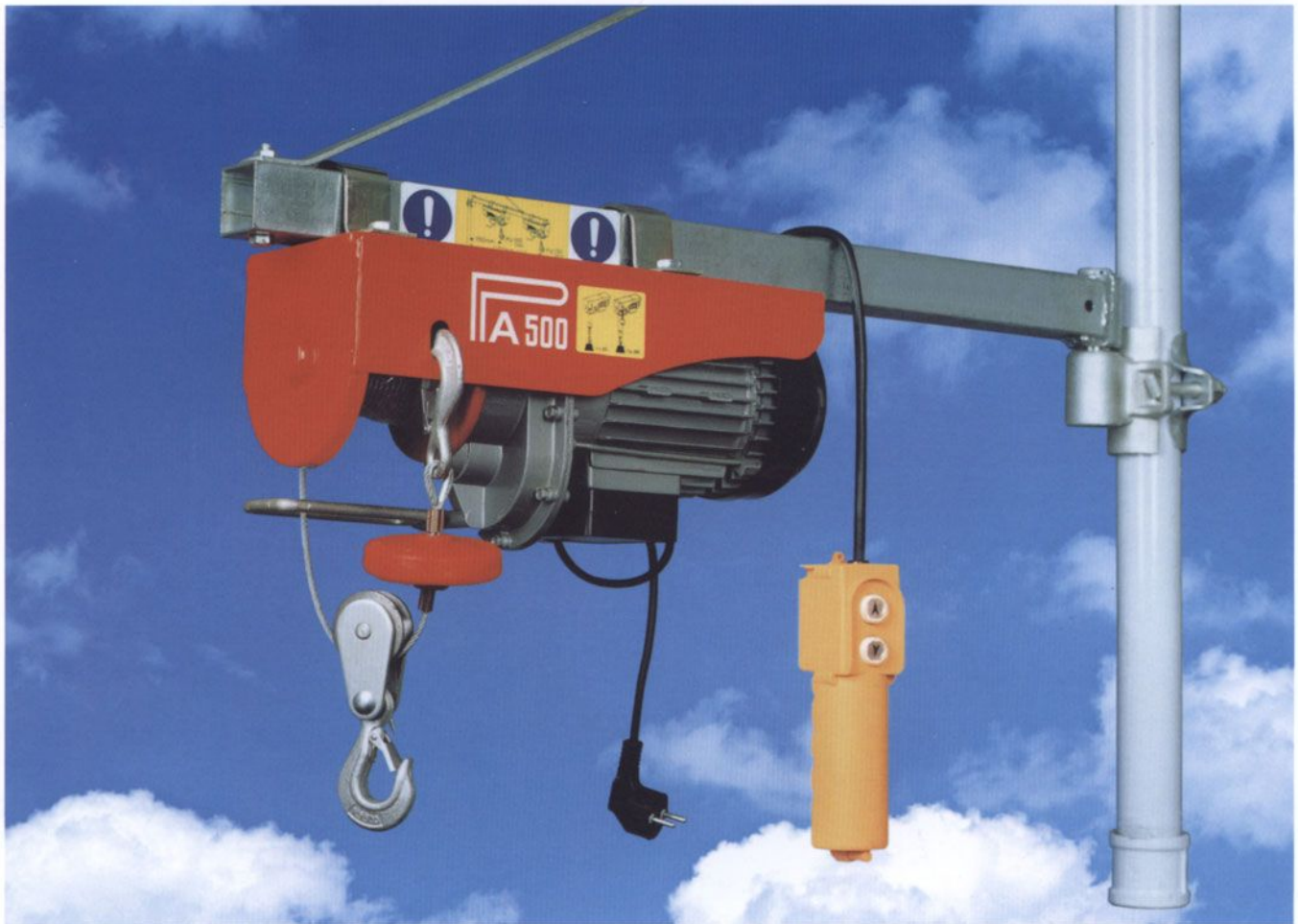

● **电动葫芦 ELECTRIC HOIST**

产品型号 Specification	使用方法 Method of use	额定电压 Rated volt(V)	输入功率 Input power (W)	额定起重量 Rated lifting weight(kg)	起升速度 Lifting speed (m/min)	起升高度 Lifting height (m)	每件数量 Quan/CTN (PCS)	包装尺码 Packing dim- ension(cm)	毛重/净重 G.W./N.W. (kg)
HGS-B200-12 PA400	单钩 Single-hook	220/230	750	200	10	12	2	52×41×17	35/33
	双钩 Double-hook			400	5	6			
HGS-B250-12 PA500	单钩 Single-hook	220/230	900	250	10	12	2	52×41×17	36/34
	双钩 Double-hook			500	5	6			
HGS-B300-12 PA600	单钩 Single-hook	220/230	1050	300	10	12	2	52×41×17	37/35
	双钩 Double-hook			600	5	6			
HGS-B350-18 PA700	单钩 Single-hook	220/230	1200	350	10	12	2	52×44×17	39/37
	双钩 Double-hook			700	5	6			
HGS-B400-18 PA800	单钩 Single-hook	220/230	1350	400	10	12	2	52×44×17	40/38
	双钩 Double-hook			800	5	6			

PA1000

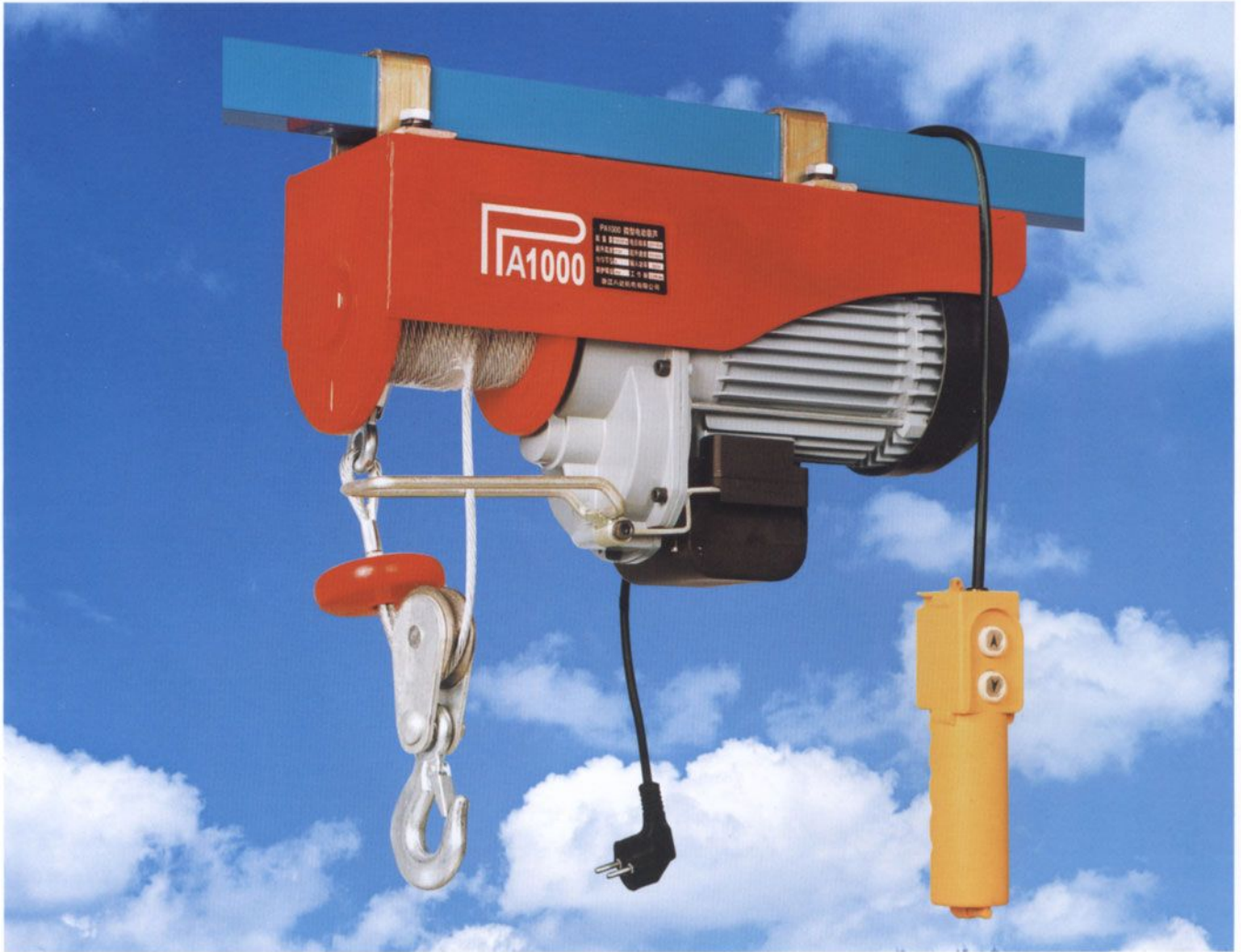

● 电动葫芦 ELECTRIC HOIST

产品型号 Specification	使用方法 Method of use	额定电压 Rated volt (V)	输入功率 Input power (W)	额定起重量 Rated lifting weight(kg)	起升速度 Lifting speed (m/min)	起升高度 Lifting height (m)	每件数量 Quan/CTN (PCS)	包装尺码 Packing dim- ension(cm)	毛重/净重 G.W./N.W. (kg)
HGS-B500-12 PA1000	单钩 Single-hook	220/230	1600	500	10	12	1	54×22×31	31/30
	双钩 Double-hook			1000	5	6			

特点: 带急停开关及强制断开限位开关,
防护等级 IP54, 带热保护装置。

Trait: with urgent stop switch and reinforced breaking switch with position limit, Protection class up to IP54, with thermal prevention device.

PA200A PA250A PA300A

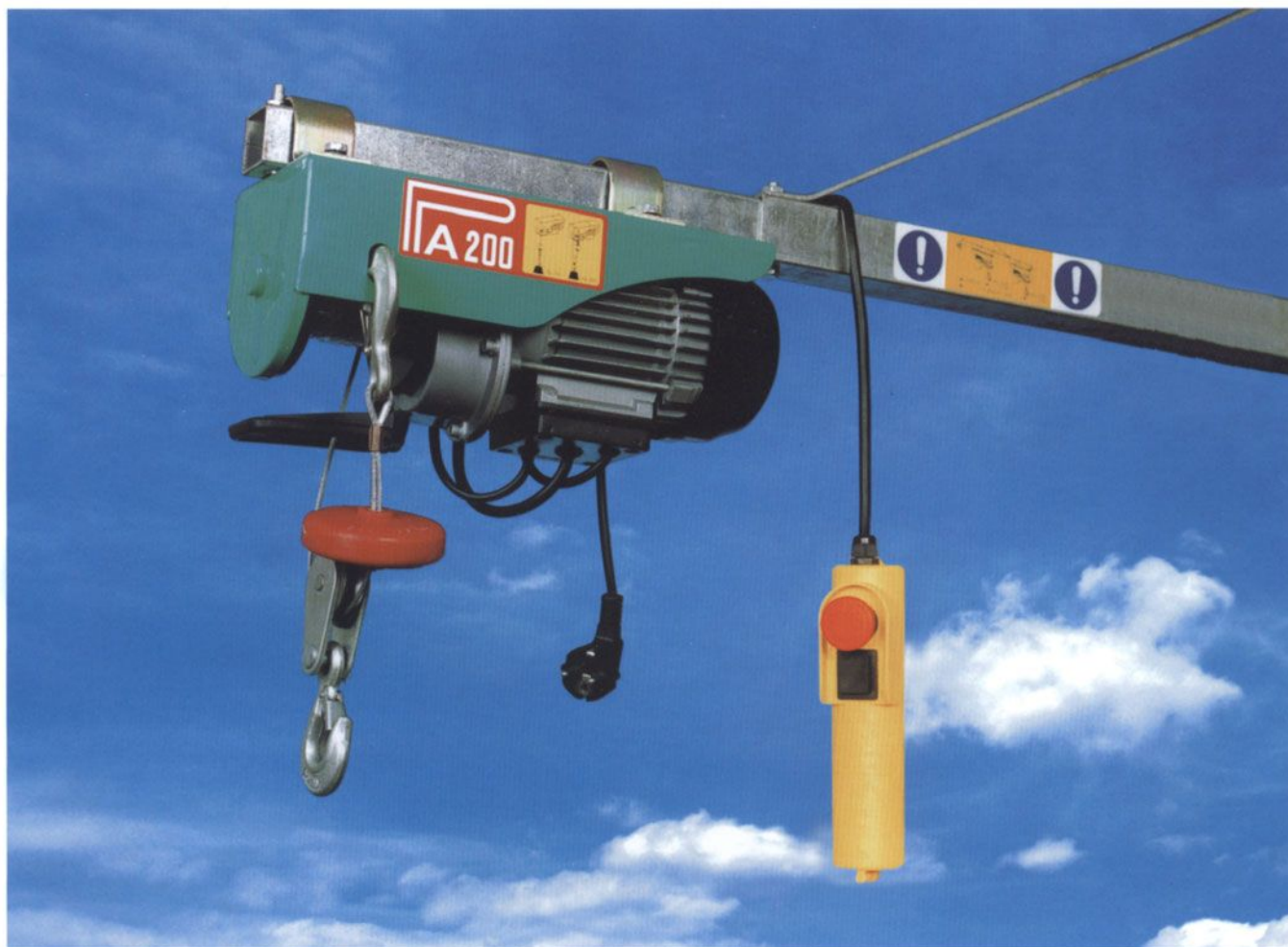

● 电动葫芦 ELECTRIC HOIST

产品型号 Specification	使用方法 Method of use	额定电压 Rated volt(V)	输入功率 Input power (W)	额定起重量 Rated lifting weight(kg)	起升速度 Lifting speed (m/min)	起升高度 Lifting height (m)	每件数量 Quan/CTN (PCS)	包装尺码 Packing dim- ension(cm)	毛重/净重 G.W./N.W. (kg)
HGS-B100-12 PA200A	单钩 Single-hook	220/230	450	100	10	12	2	46×36×16	24/22
	双钩 Double-hook			200	5	6			
HGS-B125-12 PA250A	单钩 Single-hook	220/230	500	125	10	12	2	46×36×16	25/23
	双钩 Double-hook			250	5	6			
HGS-B150-12 PA300A	单钩 Single-hook	220/230	550	150	10	12	2	46×36×16	26/24
	双钩 Double-hook			300	5	6			

特点: 带急停开关及强制断开限位开关,
防护等级 IP54, 带热保护装置。

Trait: with urgent stop switch and reinforced
breaking switch with position limit, Protection
class up to IP54, with thermal prevention device.

PA400A PA500A PA600A



● 电动葫芦 ELECTRIC HOIST

产品型号 Specification	使用方法 Method of use	额定电压 Rated volt (V)	输入功率 Input power (W)	额定起重量 Rated lifting weight(kg)	起升速度 Lifting speed (m/min)	起升高度 Lifting height (m)	每件数量 Quan/CTN (PCS)	包装尺码 Packing dim- ension(cm)	毛重/净重 G.W./N.W. (kg)
HGS-B200-12 PA400A	单钩 Single-hook	220/230	750	200	10	12	2	52×41×17	35/33
	双钩 Double-hook			400	5	6			
HGS-B250-12 PA500A	单钩 Single-hook	220/230	900	250	10	12	2	52×41×17	36/34
	双钩 Double-hook			500	5	6			
HGS-B300-12 PA600A	单钩 Single-hook	220/230	1050	300	10	12	2	52×41×17	37/35
	双钩 Double-hook			600	5	6			

特点: 带急停开关及强制断开限位开关,
防护等级IP54, 带热保护装置。

Trait: with urgent stop switch and reinforced breaking switch with position limit, Protection class up to IP54, with thermal prevention device.

PA700A PA800A

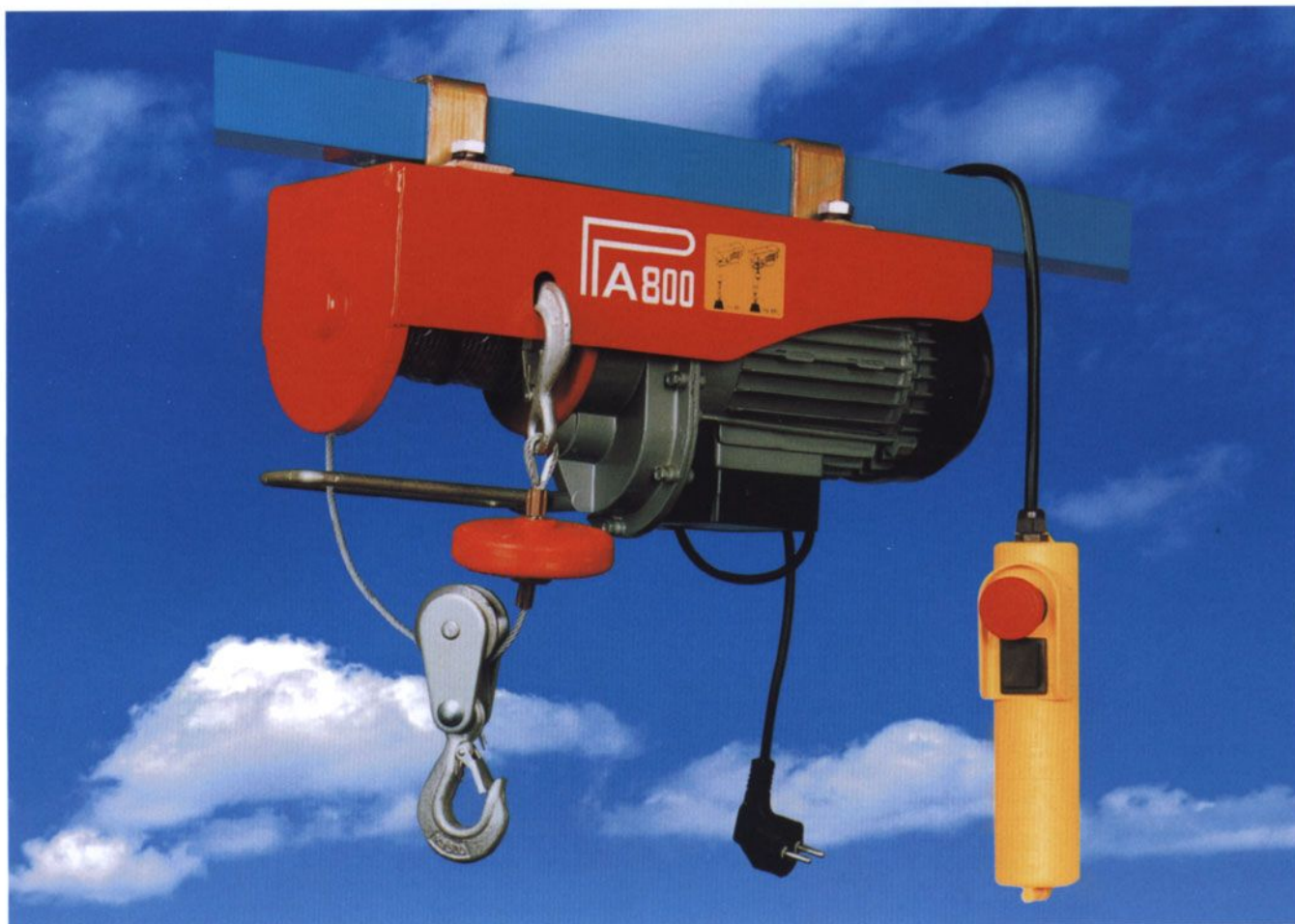

● 电动葫芦 ELECTRIC HOIST

产品型号 Specification	使用方法 Method of use	额定电压 Rated volt (V)	输入功率 Input power (W)	额定起重量 Rated lifting weight(kg)	起升速度 Lifting speed (m/min)	起升高度 Lifting height (m)	每件数量 Quan/CTN (PCS)	包装尺码 Packing dim- ension(cm)	毛重/净重 G.W./N.W. (kg)
HGS-B350-12 PA700A	单钩 Single-hook	220/230	1200	350	10	12	2	52×44×17	38/36
	双钩 Double-hook			700	5	6			
HGS-B400-12 PA800A	单钩 Single-hook	220/230	1350	400	10	12	2	52×44×17	39/37
	双钩 Double-hook			800	5	6			

特点: 带急停开关及强制断开限位开关,
防护等级IP54, 带热保护装置。

Trait: with urgent stop switch and reinforced breaking switch with position limit, Protection class up to IP54, with thermal prevention device.

PA1000A

PA1000C

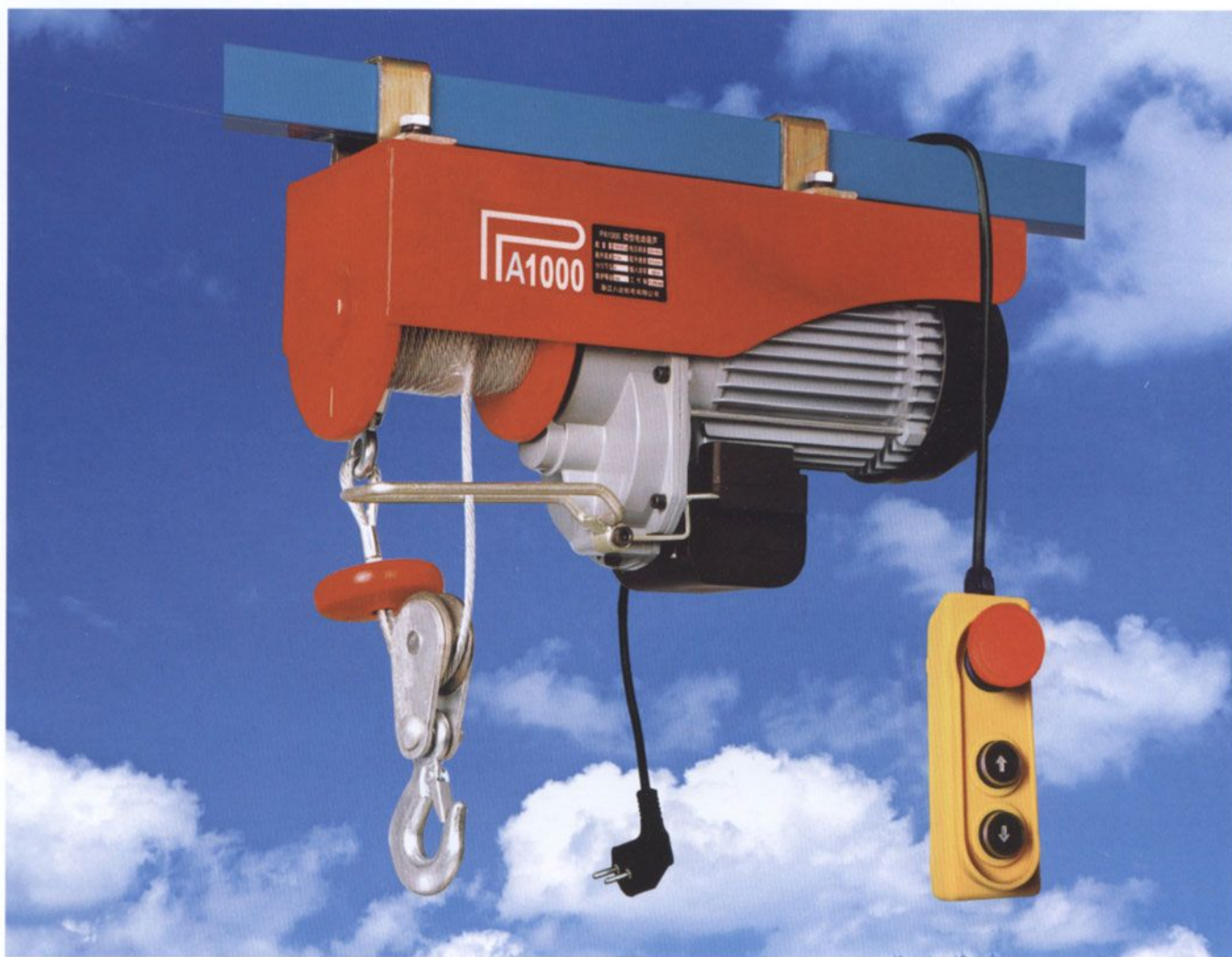

● 电动葫芦 ELECTRIC HOIST

产品型号 Specification	使用方法 Method of use	额定电压 Rated volt (V)	输入功率 Input power (W)	额定起重量 Rated lifting weight(kg)	起升速度 Lifting speed (m/min)	起升高度 Lifting height (m)	每件数量 Quan/CTN (PCS)	包装尺码 Packing dim- ension(cm)	毛重/净重 G.W./N.W. (kg)
HGS-B500-12 PA1000A	单钩 Single-hook	220/230	1600	500	10	12	1	54×22×31	34/33
	双钩 Double-hook			1000	5	6			
HGS-B500-18 PA1000C	单钩 Single-hook	220/230	1600	500	10	18	1	54×22×31	35/34
	双钩 Double-hook			1000	5	9			



PA200B PA250B PA300B

PA400B PA500B PA600B



● 电动葫芦 ELECTRIC HOIST

产品型号 Specification	使用方法 Method of use	额定电压 Rated volt (V)	输入功率 Input power (W)	额定起重量 Rated lifting weight(Lbs)	起升速度 Lifting speed (m/min)	起升高度 Lifting height (m)	每件数量 Quan/CTN (PCS)	包装尺码 Packing dim- ension(cm)	毛重/净重 G.W./N.W. (kg)
HGS-B100-12 PA200B	单钩 Single-hook	110	460	220	10	12	2	46×36×16	24/22
	双钩 Double-hook			440	5	6			
HGS-B125-12 PA250B	单钩 Single-hook	110	560	275	10	12	2	46×36×16	25/23
	双钩 Double-hook			550	5	6			
HGS-B150-12 PA300B	单钩 Single-hook	110	660	330	10	12	2	46×36×16	26/24
	双钩 Double-hook			660	5	6			
HGS-B200-12 PA400B	单钩 Single-hook	110	850	440	10	12	2	52×44×17	35/33
	双钩 Double-hook			880	5	6			
HGS-B250-12 PA500B	单钩 Single-hook	110	1050	550	10	12	2	52×44×17	36/34
	双钩 Double-hook			1100	5	6			
HGS-B300-12 PA600B	单钩 Single-hook	110	1250	660	10	12	2	52×44×17	37/35
	双钩 Double-hook			1320	5	6			

特点: 带急停开关及强制断开限位开关,
防护等级IP54, 带热保护装置。

Trait: with urgent stop switch and reinforced
breaking switch with position limit, Protection
class up to IP54, with thermal prevention device.

18M

特殊结构设计, 钢绳长度18M, 用途更广。
SPECIAL STRUCTURE, 18M STEEL WIRE, WIDE USAGE.

PA200C

PA250C

PA300C

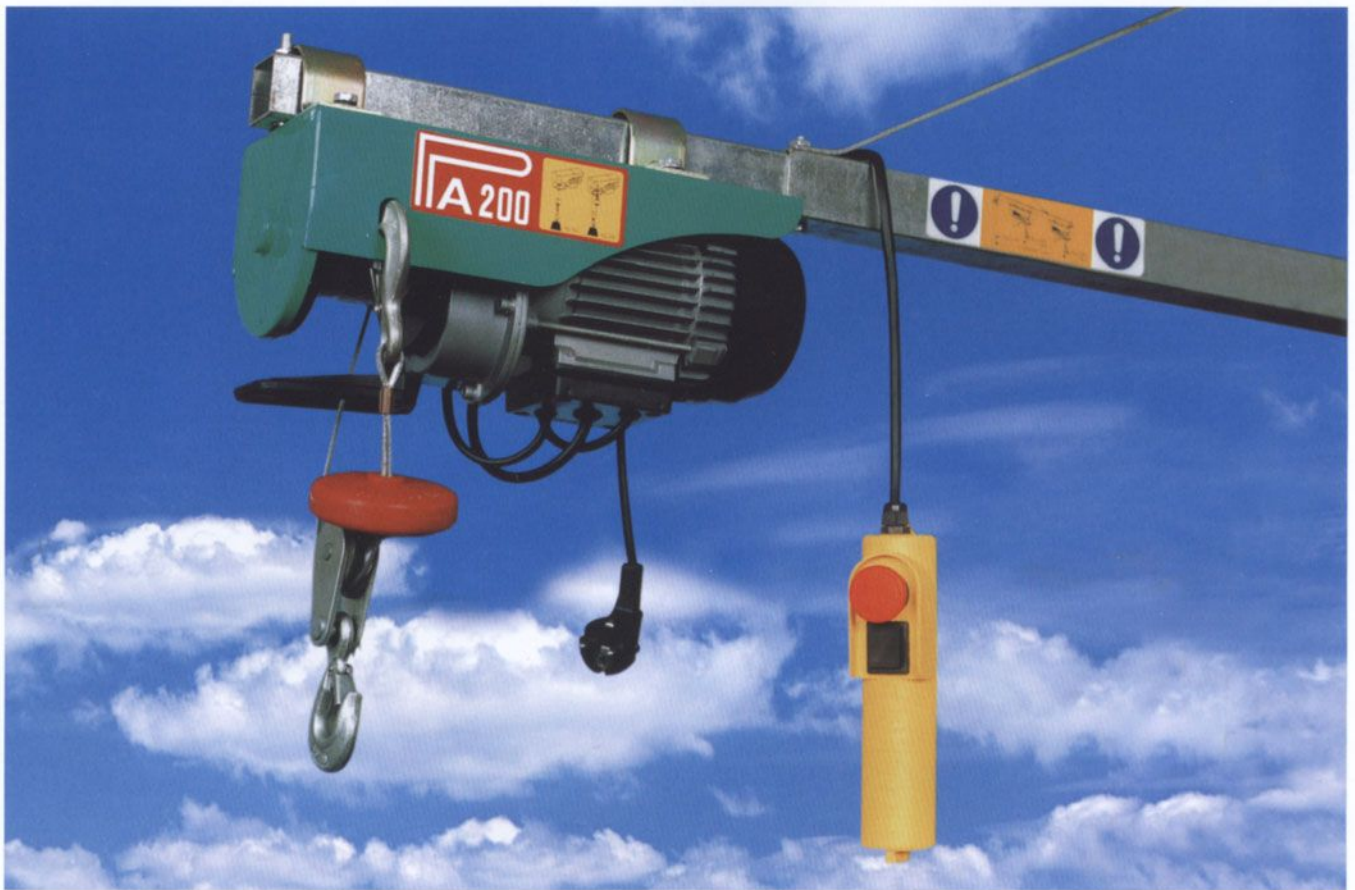

● 电动葫芦 ELECTRIC HOIST

产品型号 Specification	使用方法 Method of use	额定电压 Rated volt(V)	输入功率 Input power (W)	额定起重量 Rated lifting weight(kg)	起升速度 Lifting speed (m/min)	起升高度 Lifting height (m)	每件数量 Quan/CTN (PCS)	包装尺码 Packing dimen- sion(cm)	毛重/净重 G.W./N.W. (kg)
HGS-B100-12 PA200C	单钩 Single-hook	220/230	450	100	10	18	2	46×36×16	24/22
	双钩 Double-hook			200	5	9			
HGS-B125-12 PA250C	单钩 Single-hook	220/230	500	125	10	18	2	46×36×16	25/23
	双钩 Double-hook			250	5	9			
HGS-B150-12 PA300C	单钩 Single-hook	220/230	550	150	10	18	2	46×36×16	26/24
	双钩 Double-hook			300	5	9			

特点: 带急停开关及强制断开限位开关,
防护等级IP54, 带热保护装置。

Trait: with urgent stop switch and reinforced breaking switch with position limit, Protection class up to IP54, with thermal prevention device.

18M

特殊结构设计, 钢绳长度18M, 用途更广。
SPECIAL STRUCTURE, 18M STEEL WIRE, WIDE USAGE.

PA400C PA500C PA600C PA700C PA800C

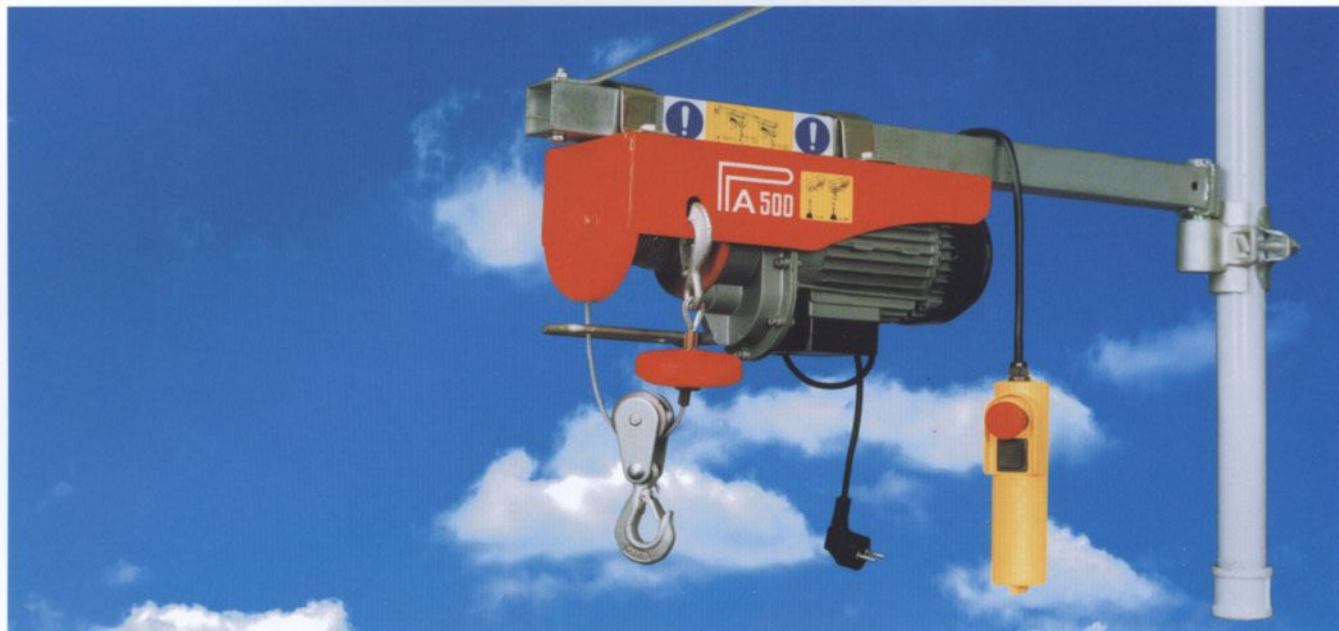

● 电动葫芦特长钢绳 ELECTRIC HOIST(EXTRA LONG STEEL WIRE)

产品型号 Specification	使用方法 Method of use	额定电压 Rated volt (V)	输入功率 Input power (W)	额定起重量 Rated lifting weight(kg)	起升速度 Lifting speed (m/min)	起升高度 Lifting height (m)	每件数量 Quan/CTN (PCS)	包装尺码 Packing dim- ension(cm)	毛重/净重 G.W./N.W. (kg)
HGS-B200-18 PA400C	单钩 Single-hook	220/230	750	200	10	18	2	52×44×17	36/34
	双钩 Double-hook			400	5	9			
HGS-B250-18 PA500C	单钩 Single-hook	220/230	900	250	10	18	2	52×44×17	37/35
	双钩 Double-hook			500	5	9			
HGS-B300-18 PA600C	单钩 Single-hook	220/230	1050	300	10	18	2	52×44×17	38/36
	双钩 Double-hook			600	5	9			
HGS-B350-18 PA700C	单钩 Single-hook	220/230	1200	350	10	18	2	52×44×17	39/37
	双钩 Double-hook			700	5	9			
HGS-B400-18 PA800C	单钩 Single-hook	220/230	1350	400	10	18	2	52×44×17	40/38
	双钩 Double-hook			800	5	9			

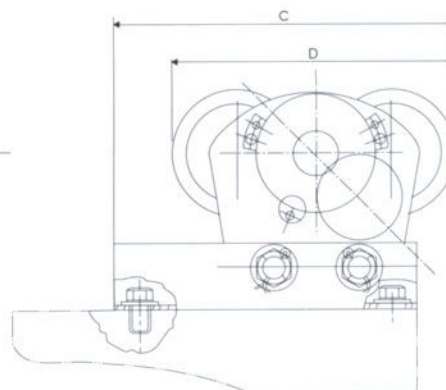
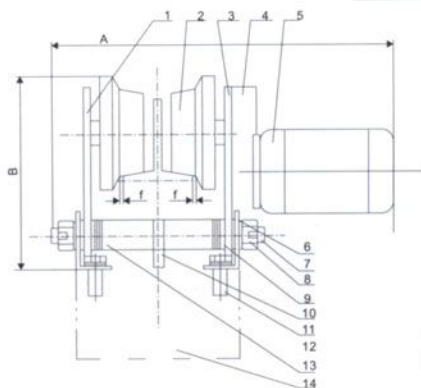
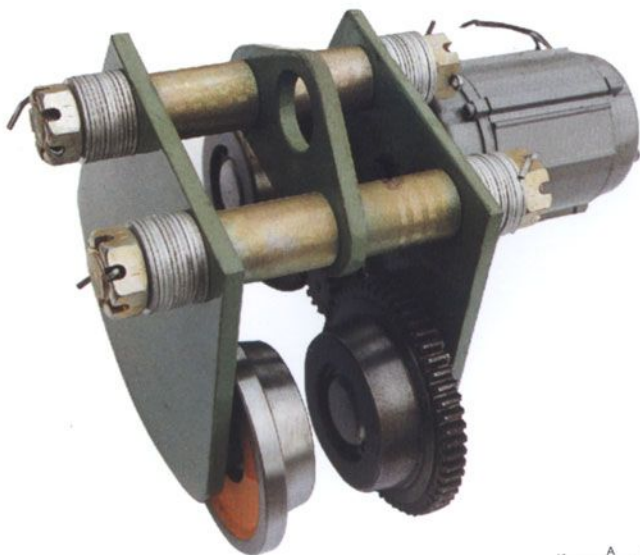

TD型单轨电动行车

Electric Trolley

规格	Specification	TD 1
额定载荷	吨 Rated loading weight	1.0t
试验载荷	吨 Tested loading weight	1.2t
标准运行高度	米 Assembling height	3m
运行速度	米/分 Moving speed	16.4m/min
电机参数 Motor data	电机型号Model of motor	D02 6324
	功率Power	120w
	转速Speed	1400r/min
能通过的最小弯道半径 Min radius of crooked track which can pass		1m
主要尺寸 Main measurement	A	340mm
	B	203mm
	C	314mm
	D	253mm
	F	2mm
推荐用工字钢 "I" steel beam recommended	工字钢号 Model of steel beam	10-22
	轨宽 Width of track	68-110mm
净重	公斤 N.W	16kg

用途:

TD系列微型电动行车以电动机驱动,行走于工字钢的轨道下缘处,配以电动葫芦或手拉葫芦便可组成桥式、单梁或悬臂式起重机。它广泛地适用于工厂、矿山、码头、仓库、建筑工地等用于安装机器设备,吊运货物的场合。

Application:

TD mini-electrical driving and engine driving, running on the down edge of the H shaped track, combined with the electrical calabash or hand dragged calabash to be formed into the lane with bridge, single-rail or arm-suspended style. They can be widely used in the hang-transportation occasions for mounting the machine and equipments in workshop, mining, dock, warehouse and construction sites.

行吊环链电动葫芦系列 Moving Chain Hoist Series

HHDD-H0.5—HHDD-K3



技术参数 TECHNIQUE PARAMETER

产品型号 Model	额定载荷 Rated Load (kg)	起升高度 Lifting Height (m)	起升速度 Lifting Speed (m/min)	链条规格 Lifting Chain (mm × m)	电源 Power Source (V)	葫芦功率 Hoist Power (kw)	行车功率 Trolley Power (kw)	行车速度 Moving Speed (min)	控制电压 Handle Control Voltage (VAC)	通过最小 弯道半径 Min Radius of Crooked Track Which Can Pass (m)	工字钢号 Model of Steel Beam	轨宽 Width of Track (mm)	重量 N. W. (kg)	工作制 Work Rate
HHDD-K1	1000	6	7.2										126	
HHDD-K2	2000	3	3.6		220/380	1.5	0.6	20	24	2	25a-45a	100-150	128	S3 - 30% 20min
HHDD-K3	3000		2.4	7.1 × 21	420/440								142	
HHDD-H0.5	500	6	7.2		100/110	0.85	0.24						126	
HHDD-H1	1000	3	3.6		120/220			230/240	20a-32a	128				

环链电动葫芦系列 Round Chain Electric Hoist Series

HHXG-H0.5—HHXG-K5



特点

★机架采用冲压件结构，轻巧灵活，结构紧凑，上下限位装置，相序保护装置，电磁制动装置。

FEATURES

★This organic adopts pressing principle, legerity and agility, up and down position limit protection device ,phase protection device and electromagnetic brake device.

技术参数 TECHNIQUE PARAMETER

产品型号 Model	额定负载 Rated Load (kg)	额定电压 Rated Volt (V)	手柄控制电压 Handle Control Voltage (V)	起重链 Lifting Chain (Φmm×m)	电机功率 Power (kw)	起升速度 Lifting Speed (m/min)	起升高度 Lifting Height (m)	电机负持续率 Motor Load (%)	净重 N.W. (kg)
HHXG-H0.5	500	100/110/120			0.85	7.2	6		62
HHXG-H1	1000	220/230/240; 50/60Hz				3.6	3		
HHXG-K1						7.2	6		64
HHXG-K2	2000	220/380	24	7.1×21		3.6		40	
HHXG-K3	3000	420/440; 50/60Hz			1.5	2.4	3		79
HHXG-K5	5000					1.4			90

悬挂式微型电动葫芦系列 Suspending Mini Electric Hoist Series

特点: 带急停开关及强制断开限位开关, 防护等级IP54, 带热保护装置
Trait: with urgent stop switch and reinforced breaking switch with position limit, Protection class up to IP54, with thermal protection device

HXS-100F—HXS-250F

特征

- ★活动自如的轻量和小盒设计
- ★当拉绳接触限位臂, 自动停止提升。
- ★当绳子反旋时, 感应臂制动电机。
- ★静动共用的负荷活动间设置。
- ★家用电源上的操作。
- ★轻便的灯芯插座。
- ★带有安全勾锁的360度万能连接勾垫。

应用

- ★内置安全设施的绞盘, 自如控制提升, 用于仓库、仓储区、房屋区、建专场所、工作场所和轻工业制造。

FEATURES

- ★Light weight & compact design allow mounting convenient.
- ★When rope touches the limit arm, stop automatically.
- ★Induction-motor stops when the rope is reverse wound.
- ★Dynamic brake designs for both static and dynamic loading.
- ★It operates on household power source.
- ★Plug-in cords allow portability with easy.
- ★360° universal joint saddle hook with safety latch.

APPLICATIONS

- ★Mini Winch with built-in safety devices feature easy control of lifting for a wide range of applicability for ware houses, storage areas, factories, house areas, construction sites, job sites and plumbings.

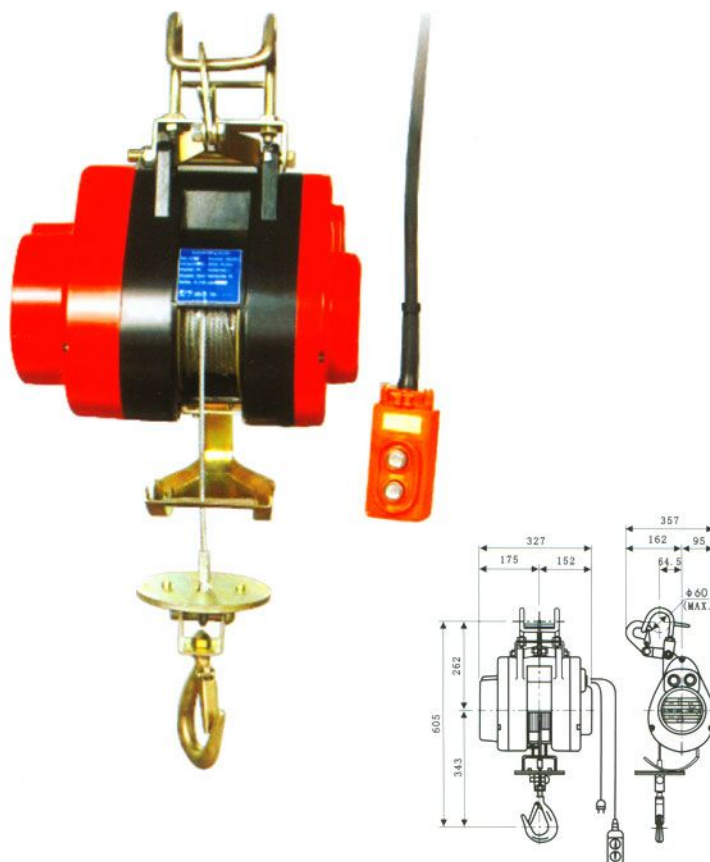

技术参数 TECHNIQUE PARAMETER

产品型号 Model	额定载荷 Rated Load (kg)	额定电压 Rated Volt (V)	输入功率 Input Power (W)	钢丝绳直径 Cable Diameter (mm)	起升速度 Lifting Speed (m/min)	起升高度 Lifting Height (m)	毛重/净重 G.W./N.W. (kg)	包装尺寸 Packing Size (mm)
HXS-100F	100	100 / 110 / 120	580	Φ3.8	15		28 / 27	
HXS-150F	150	220 / 230 / 240;	780			20		430 × 370 × 370
HXS-200F	200	50 / 60Hz	1050	Φ4.2	12		30 / 29	
HXS-250F	250		1200					

The rated load is based on the last layer of wire rope. 负荷率以绳径的最后层计算

★ 标准配件 STANDARD ACCESSORIES



★ 可选配件 OPTIONAL ACCESSORIES

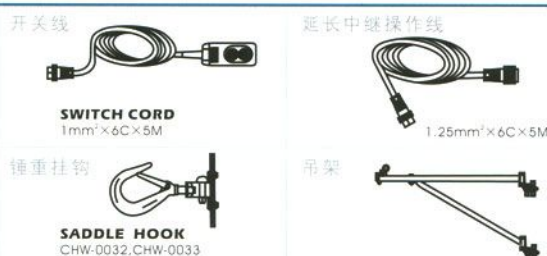

★ 吊绳 MOUNTINGS

- (A) Hang Type 吊型
Mount it on firm and stable bar. 横杆吊
- (B) Arm Type 臂型
Mount it on an optional crane
用可选用的起重机吊

电动绞盘系列 Electric Winch Series



KDJ-5000L—KDJ-9000L



KDJ-5000N—KDJ-9000N



KDJ-10000L—KDJ-12000L



KDJ-10000N—KDJ-12000N

技术参数 TECHNIQUE PARAMETER

产品型号 Model	电压 Volt (V)	输入功率 Input Power (kw)	最大拉力 Max. Line Pull (lbs)	钢索 Steel Cable (φ mm×m)	每件数量 Qty./CTN (pcs)	包装尺码 Packing Size (mm)	毛重/净重 G.W./N.W. (kg)
KDJ-5000N	12	2.76	5000	6×24	1	525×340×335	27/25
KDJ-5000L							26/24
KDJ-6000N							3.6
KDJ-6000L		31/29					
KDJ-8000N		4.2	8000	8×29			
KDJ-8000L							31/29
KDJ-9000N						3.6	9000
KDJ-9000L		41/39					
KDJ-10000N		4.2	10000	9.2×26			
KDJ-10000L						43/41	
KDJ-12000N						12000	10.2×26.5
KDJ-12000L		60/58					

电动绞盘系列 Electric Winch Series

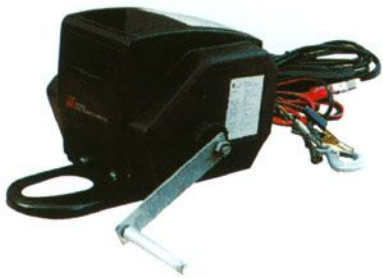

KDJ-2000G—KDJ-2500G



KDJ-2000H—KDJ-2500H



KDJ-3000H—KDJ-3500H



KDJ-3500K—KDJ-4500K

技术参数 TECHNIQUE PARAMETER

产品型号 Model	电压 Volt (V)	输入功率 Input Power (kw)	最大拉力 Max. Line Pull (lbs)	钢索 Steel Cable (φ mm×m)	每件数量 Qty./CTN (pcs)	包装尺码 Packing Size (mm)	毛重/净重 G.W./N.W. (kg)
KDJ-2000G	12	0.3	2000	4.8×9	2	590×360×250	24/22
KDJ-2500G		0.4	2500				
KDJ-2000H		1.08	2000	4×15	555×415×235	23/18.5	
KDJ-2500H		1.8	2500	4.8×14			
KDJ-3000H		2.4	3000	5.4×13			23.5/19
KDJ-3500H		2.76	3500				
KDJ-3500K		1	3.72	4500	6×15	470×280×220	19/18
KDJ-4500K							

电动行车系列 Electric Trolley Series



技术参数 TECHNIQUE PARAMETER

规格 Specification		TD1B	TD3B
额定载荷 吨	Rated Loading Weight(t)	≤1	≤3
标准运行高度 米	Assembling Height(m)		3~6
运行速度 米/分	Moving Speed(m/min)		20
电机参数 Motor parameter	电机型号 Power Source(V)	110/120/220/240; 50/60Hz	220/380/440; 50/60Hz
	功率 Power(W)	450	600
	转速 Speed(r/min)		2800
能通过的最小弯道半径m Min Radius of Crooked Track Which Can Pass(m)			2
推荐用工字钢 “工” Steel Beam Recommended	工字钢号 Model of Steel Beam		20a~45a
	轨宽mm Width of Track(mm)		100~150
净重 N.W.(kg)			66
控制电压 VAC	Handie Control Voltage(v)		24



BDH 环链电动葫芦

BDH Electric Chain Hoist

特点：

采用吊钩悬挂式或吊环悬挂式安装；
采用机械制动和上下行程开关控制；
采用高强度起重环链使用寿命更长；
采用110V、230V单相电源。

Features:

It adopts the installation of hook hanging or ring hanging device
It adopts mechanical brake and controlled by up and down stroke switch.
It adopts high strength chain with long life of span.
It adopts single-phase power.

产品型号 Specification	起重量 Lifting weight	功率 Power	链速度 Chain Speed	链长 Chain Length	电压 Voltage	链直径 Chain Diameter
	单钩 Single-hook		单钩 Single-hook			
BDH-100	100kg	150w	3m/min	3m	110V60Hz	Φ5
BDH-150	150kg	220w	3m/min	3m	110V60Hz	Φ5
BDH-250	250kg	350w	3m/min	3m	110V60Hz	Φ5
BDH-100	100kg	130w	3m/min	3m	230V50Hz	Φ5
BDH-150	150kg	190w	3m/min	3m	230V50Hz	Φ5
BDH-250	250kg	300w	3m/min	3m	230V50Hz	Φ5

BDH-500环链电动葫芦

BDH-500 Electric Chain Hoist

特点：

采用吊钩悬挂式或吊环悬挂式安装；
采用机械制动和安全离合器；
采用高强度起重环链使用寿命更长；
采用110V、230V交流单相电源。

Features:

It adopts the installation of hook hanging or ring hanging device
It adopts mechanical brake and safety clutch.
It adopts high strength chain with long life of span.
It adopts single-phase power



产品型号 Specification	起重量 Lifting weight	功率 Power	链速度 Chain Speed	链长 Chain Length	电压 Voltage	链直径 Chain Diameter
	单钩 Single-hook		单钩 Single-hook			
BDH-500	500kg	500W	3m/min	3m	110V60Hz	Φ6.3
BDH-500	500kg	500W	3m/min	3m	230V50Hz	Φ6.3

液压高效钢管切断机

Hydraulic Pressure High-effective Reinforcing Steel Bar Cutter



OY-16



OY-19



OY-22



OY-25

技术参数 TECHNIQUE PARAMETER

产品型号 Model	最大切断力 Max Cutting Force		直径 Diameter(mm)	额定电压 Rated Volt (V)	额定消耗功率 Rated Power (W)	切断速度 Cut-Off Speed (s)	标准附属品 Standard Accessories	包装尺寸 Packing Size (mm)	毛重/净重 G.W./N.W. (kg)
	SD345民异型钢筋 SD345All Type Reinforcing Steel Bar	PC钢筋 PC Steel Bar HRC36	弹簧钢 Spring Steel HRC52						
OY-16	φ16	φ14	φ9	110/120/	780	≈2.5	铁箱 Iron box	500×250×160	15/13
OY-19	φ19	φ16	φ11	220/230/	850	≈3.0		500×260×200	17/15
OY-22	φ22	φ19	φ12	240;		≈3.8		500×260×200	18/16
OY-25	φ25		φ14	50/60Hz	1050			600×300×260	22/20