

## WATER SYSTEMS ECODIVER



 **DAB PUMPS LTD.**  
Unit 4, Stortford Hall Industrial  
Park Dunmow Road, Bishops Stortford, Herts  
CM23 5GZ - UK  
info.uk&eire@dwtgroup.com  
Tel.: +44 1279 652 776  
Fax: +44 1279 657 727

 **DAB PUMPS B.V.**  
Albert Einsteinweg, 4  
5151 DL Drunen - Nederland  
info.netherlands@dwtgroup.com  
Tel.: +31 416 387280  
Fax: +31 416 387299

 **DAB PUMPS B.V.**  
Brusselstraat 150  
B-1702 Groot-Bijgaarden - Belgium  
info.belgium@dwtgroup.com  
Tel.: +32 2 4668353  
Fax: +32 2 4669218

 **DAB PUMPEN DEUTSCHLAND GmbH**  
Tackweg 11  
D - 47918 Tönisvorst - Germany  
info.germany@dwtgroup.com  
Tel.: +49 2151 82136-0  
Fax: +49 2151 82136-36

 **DAB PUMPS INC.**  
3226 Benchmark Drive  
Ladson, SC 29456 USA  
info.usa@dwtgroup.com  
Ph. : 1-843-797-5002  
Fax : 1-843-797-3366

 **DAB PUMPS IBERICA S.L.**  
Parque Empresarial San Fernando  
Edificio Italia Planta 1ª  
28830 - San Fernando De Henares - Madrid  
Spain  
info.spain@dwtgroup.com  
Ph.: +34 91 6569545  
Fax: +34 91 6569676

 **DWT GROUP Russia**  
100 bldg. 3 Dmitrovskoe highway,  
127247 Moscow - Russia  
info.russia@dwtgroup.com  
Tel.: +7 495 739 52 50  
Fax: +7 495 485-3618

 **DAB PUMPS CHINA**  
Shandong Sheng Qingdao Shi  
Jinji Jishu Kaifaqu Kaituo Rd  
ZIP PC266510  
CN - China  
info.china@dwtgroup.com  
Tel.: +8613608963089  
Fax: +8653286812210

# ECODIVER

# HYDRAULIC DATA

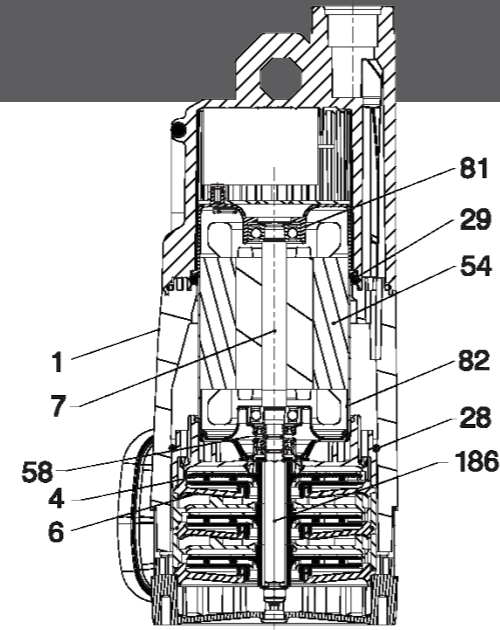

TECHNICAL DATA		
CONSTRUCTION		
No.	Description	Material
1	Pump Body	PP OMO 30% FVAC
4	Impeller	PPO/PPE 20% FV
6	Diffuser	PPO/PPE 20% FV
7	Rotor Shaft	INOX AISI 416
28	O Ring	NBR 70
29	O Ring	NBR 70
54	Motor Casing	fe PO1 0.65mm
58	Ceramic Bush	INOX AISI 416
81	Upper Bearing Support	Cast Aluminum
82	Lower Bearing Support	Cast Aluminum
186	Pump Shaft	Hexagonal AISI 303

TECHNICAL DATA	
FEATURES & BENEFITS	
<ul style="list-style-type: none"> <li>• Plug &amp; Play</li> <li>• Large range to cover various requirements</li> <li>• Provides Excellent flows "In a compact design"</li> <li>• Efficient motors</li> <li>• 115v 60Hz</li> <li>• CSA and UL approved</li> <li>• Dry Run protection (with Float Switch)</li> <li>• Built in thermic overload</li> </ul>	

## APPLICATIONS

Powerfull Multi-stage Submersible Pumps  
 Available with 2,3 and 4 impellers. Suitable to pump clear water. Manufactured with anti-corrosive and rust-proof materials. Motor with thermic overload protection. Wear resistant shaft. Anti-debris stainless steel strainer.

The excellent cooling of the motor that enables the pump to operate even when it is partially submerged. An automatic version is available with a start/ stop float switch. Supplied with power cable with plug, non return valve and 4-step fitting.

- ideal for
- rain water systems
  - operating sprinklers
  - pumping water from tanks & cisterns,
  - pumping water from ponds and wells
  - other applications that require high pressure

## TECHNICAL DATA

Model	HP	Watts	Volts	Frequency	Amps	FloatSwitch	MaxFlow	Max Head	Impellers	Max PSI
ECODIVER 750	1/2	750	115	60 Hz	6.8	No	25 gpm	79 ft	2	35
ECODIVER 750-A						Yes				
ECODIVER 1000	3/4	900	115	60 Hz	8.4	No		118 ft	3	52
ECODIVER 1000-A						Yes				
ECODIVER 1200	1	1100	115	60 Hz	9.8	No				
ECODIVER 1200-A						Yes				

## TECHNICAL DATA

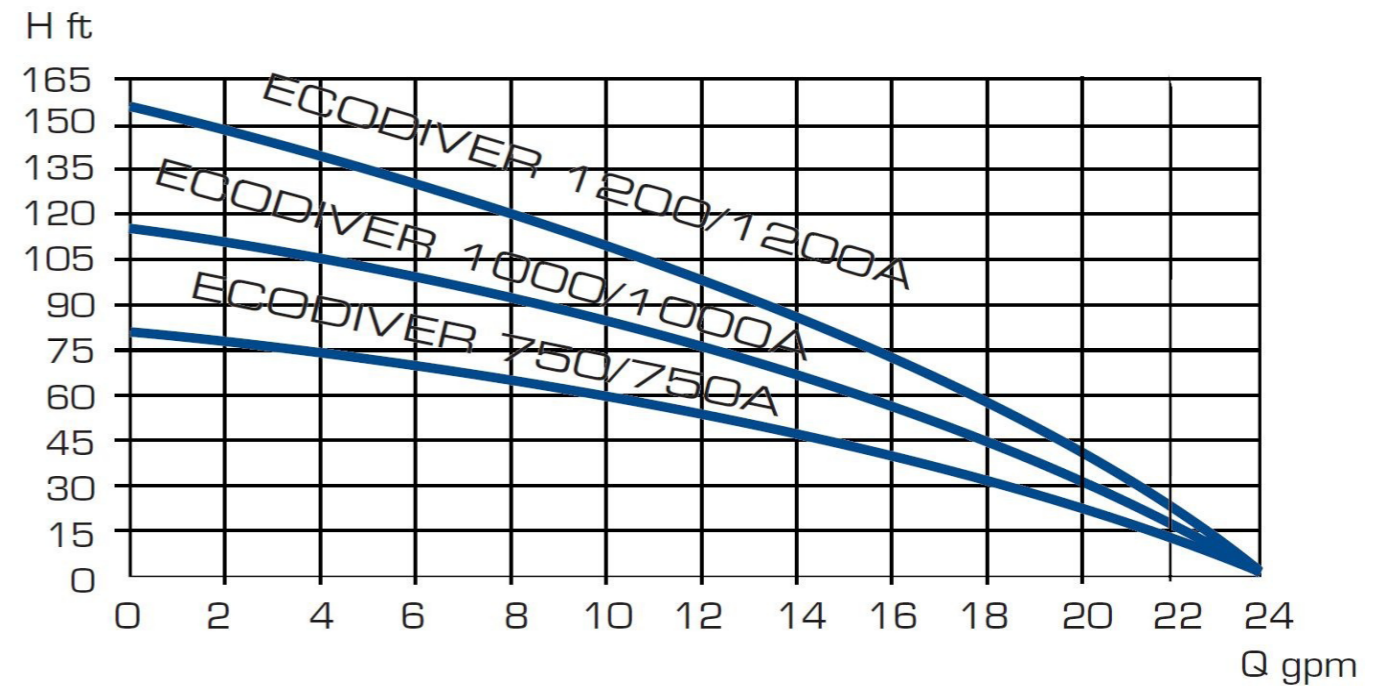

## DIMENSIONS

Model	H	H1	A	ØB	Weight	Pallet Qty
ECODIVER 750	13.8"	11.5"	5.9"	1"	16.0 lbs	40
ECODIVER 750-A	13.8"	11.5"	5.9"	1"	16.5 lbs	
ECODIVER 1000	14.8"	12.5"	5.9"	1"	18.7 lbs	
ECODIVER 1000-A	14.8"	12.5"	5.9"	1"	19.1 lbs	
ECODIVER 1200	15.8"	13.5"	5.9"	1"	19.4 lbs	
ECODIVER 1200-A	15.8"	13.5"	5.9"	1"	19.8 lbs	

